



MX1500TXSEE

Programmable Hi-Power Blender with Sound Enclosure and 1.9 Lt., BPA-Free Copolyester Container



*Made in USA with US and foreign parts.

ELECTRICAL

Voltage: 230

Frequency: 50Hz

Watts: 1560

Amps: 6.8

Plug Type: 10 Amp

Cord Length: 1.8 mt



MAIN FEATURES

- Heavy-duty, 3.5 peak HP, high-performance motor with 2-speed selection is the strongest in its class. It powers through the toughest ice and frozen fruit mixtures in seconds
- Super-high, 45,000 RPM motor speed for the smoothest consistencies
- 4 reprogrammable beverage stations for perfect results every time
 - Factory-set programs for the most popular beverage types
 - Easy to create your own customized programs—fully reprogrammable directly on the keyboard. No need for a USB or computer for programming
- Daily and total drink counter display
- Dual PULSE feature with reprogrammable speed control
- Easy-to-clean, electronic-membrane keypad
- Sound enclosure included for noise reduction
- The Raptor® 1.9 Lt., stackable, unbreakable, dishwasher-safe, BPA-free copolyester container
- Ultra-aggressive blade and jar design deliver smoother consistencies and faster results
- High-performance, high-impact, stainless steel blade is user replaceable for easy servicing
- User-replaceable, metal-on-metal, stainless steel coupling system for durability and reliability
- Easily removable container cover with removable clear cap lets you add ingredients and reduce pressure during hot food blending.
- One-piece, dishwasher-safe, removable jar pad
- Recommended for 75+ drinks per day
- Limited Three-Year Motor Warranty and Two-Year Parts & Labor Warranty

SALES FEATURES

Get smooth, consistent results with the Waring® MX1500TX. This heavy-duty, 3.5 HP blender maximizes power and efficiency using The Raptor® blade and jar assembly. Blend frozen drinks, sauces, soups and more. An easy-to-clean, electronic-membrane keypad with blue backlit LCD screen, adjustable speed controls and four reprogrammable beverage stations make it perfect for restaurants, health facilities, schools or coffee shops.

Programmable Hi-Power Blender with Sound Enclosure and 1.9 Lt., BPA-Free Copolyester Container

MX1500TX



@waringcommercial

waringcommercialproducts.com



Programmable Hi-Power Blender with Sound Enclosure and 1.9 Lt., BPA-Free Copolyester Container MX1500TXSEE

PARTS & ACCESSORIES

- | | | | |
|---|---|---|--|
|  | CAC90
1.9 Lt. Stainless Steel Container |  | CAC95-12
1.9 Lt. Green Copolyester Container |
|  | CAC93X
1.4 Lt. Copolyester Container |  | CAC95-28
1.9 Lt. Orange Copolyester Container |
|  | CAC93X-03
1.4 Lt. Yellow Copolyester Container |  | CAC116
Blending Assembly Kit and Retainer Ring Kit |
|  | CAC93X-06
1.4 Lt. Blue Copolyester Container |  | CAC119
Retainer Ring Wrench |
|  | CAC93X-10
1.4 Lt. Purple Copolyester Container |  | CAC158
Blending Assembly Kit |
|  | CAC93X-12
1.4 Lt. Green Copolyester Container |  | CAC159
Retainer Ring Kit |
|  | CAC93X-28
1.4 Lt. Orange Copolyester Container |  | CAC160
Drive Coupling |
|  | CAC95
The Raptor® – Aggressive, All-Purpose, Stackable, 1.9 Lt., BPA-Free Copolyester Container |  | CAC161
Drive Coupling Removal Tool |
|  | CAC95-03
1.9 Lt. Yellow Copolyester Container |  | CAC169
Spatula – Custom designed for use with MX Series Blenders |
|  | CAC95-06
1.9 Lt. Blue Copolyester Container |  | SE1000
Large Sound Enclosure |
|  | CAC95-10
1.9 Lt. Purple Copolyester Container |  | SE500
Small Sound Enclosure |

DIMENSIONS

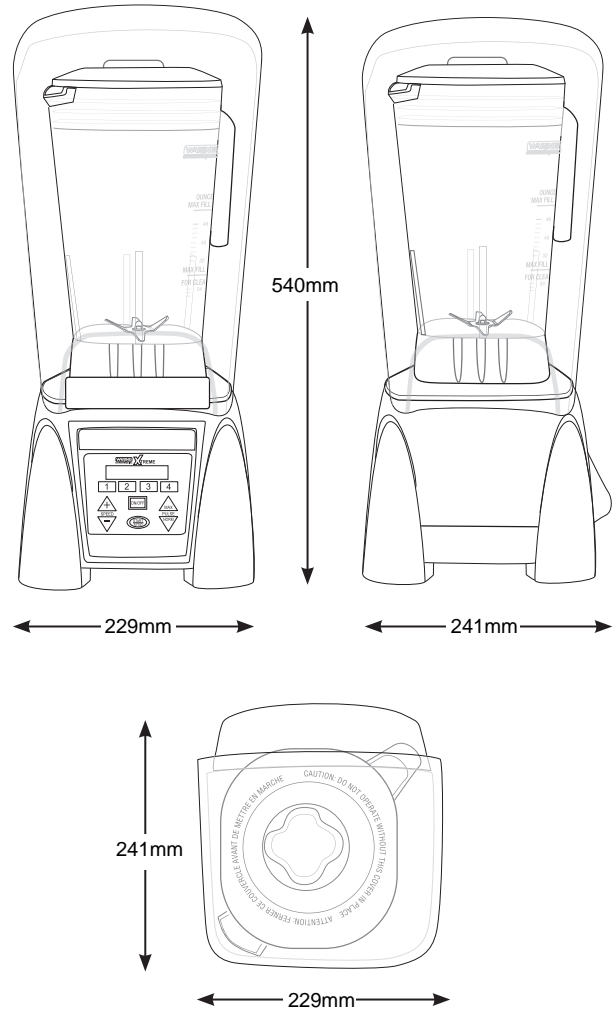

Out of Box Weight: 9.7 kg.

ORDERING INFORMATION	#STD. PKG.	GIFTBOX WEIGHT	CUBIC MT	BOX DIMENSIONS D X W X H	UPC	CASE PKG.			
MX1500TX– Programmable Hi-Power Blender with Sound Enclosure, 64 oz., BPA-Free Copolyester Container	1	11 kg	0.06	51.8 x 29.8 x 42 cm	040072017032	1			



@waringcommercial

waringcommercialproducts.com